

CLG2015L

PALLET TRUCK

POWER TYPE
Electric

BATTERY
Lithium-Ion

CAPACITY
3,300 lb (1,500 kg)

VOLTAGE
24 Volt



**XTRACARE
WARRANTY**

SPECIFICATIONS

EXCLUSIVELY FOR DEALER

GENERAL

Power type	Electric
Driving type	Walkie
Capacity	Q 3,300 lb (1,500 kg)
Load center	c 24 in (600 mm)
Overhang	x 37.3 in (947mm)
Wheel base	y 46.7 in (1,185 mm)

WEIGHTS

Service weight	271 lb (123 kg)	278 lb (126 kg)
Loading axle load, driving/loading	1,102/2,476 lb (500/1123 kg)	1,380/2,205 lb (626/1,000 kg)
Unloading axle load, driving/loading	212/60 lb (96/27 kg)	218/60 lb (99/27 kg)

CHASSIS

Wheel	Polyurethane	
Driving wheel size	x w	8.25x2.75 in (210x70 mm)
Loading wheel size	x w	3.15x3.66 in(80x93 mm)
Balance wheel size	x w	3.15x1.18 in (80x30 mm)
Wheels (x= driving wheel) driving/loading	1x/ 2(1x/ 4) or 1x +2/ 2(1x +2/ 4)	
Driving tread width	b10	- / 16.5 in (420 mm)
Loading tread width	b11	15.0 in(380 mm) 20.7 in (525 mm)

DIMENSIONS

Lifting height	h3	4.5 in (115 mm)
Handle height, min / max	h14	27.5 in (700 mm) 45.7 in (1,160 mm)
Fork height	h13	3.15 in (80 mm)
Overall length	l1	60.2 in (1530 mm)
Body length	i2	15.0 in (380 mm)
Overall width	b1	21.3 in (540 mm) 27.0 in (685 mm)
Fork size	s/e/l	1.9/6.3/45.3 in (47/160/1,150 mm)
Fork spread	b5	21.3 in (540 mm) 27.0 in (685 mm)
Min ground clearance	m2	1.3 in (33 mm)
Aisle width, 800x1200 pallet	ast	78.7 in (2,000 mm)
Turning radius	wa	52.4in (1,330 mm)

Performance

Driving speed (load/unload)	2.8 mph (4.6 km) / 3.0 mph (4.8 s)
Lifting speed (load / unload)	0.8 in (20 mm) / 1.0 s (25 s)
Lower speed (load / unload)	2.0 in (50 mm) / 1.6 s (40 s)
Max. gradeability (load / unload)	4 / 16 %
Brake system	electromagnetic

Systems

Driving motor power, S2 60min	0.9 hp (0.65 kw)
Lifting motor power, S3 10%	0.7 hp (0.50 kW)
Battery according DIN 43531/ 35/ 36 A, B, C standard	No
Battery capacity/voltage	20 ah / 24 v
Battery weight (+/-5%)	10.1 lb (4.6 kg)
Energy consumption (according VDI)	0.25 hph/h (0.18 kWh/h)

Other

Driving control type	DC
Ear noise	<70 dB (A)

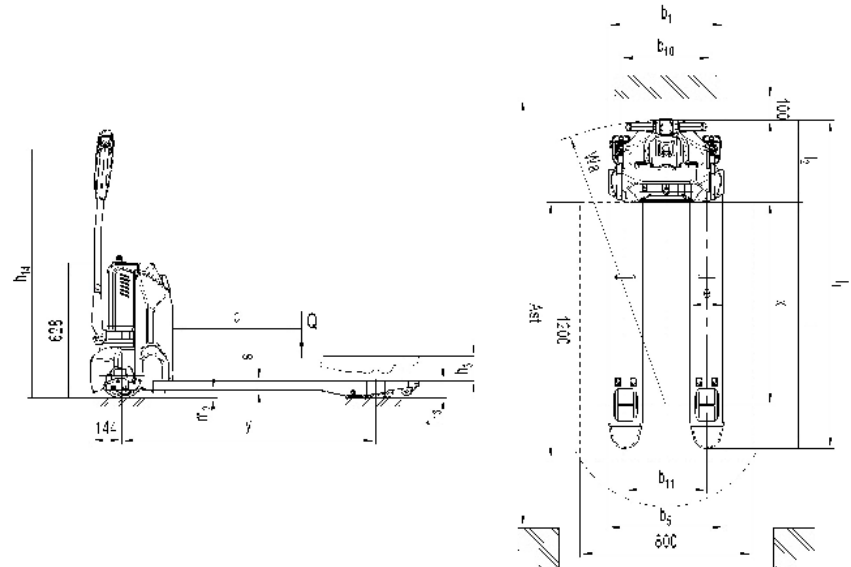

LGNA-SS-CLG2015L-20211011-ENG-US

Specifications and designs are subject to change without notice. Machines shown may include optional equipment.

LiuGong Construction Machinery N.A., LLC.
22220 Merchants Way - Suite 100
Katy, TX 77449
USA

T: 281-579-8882
www.liugongna.com

F: 281-579-8388