

# S4046DE

AERIAL WORK PLATFORM

PLATFORM HEIGHT  
Min/Max: 5/39 ft

RAISING/FALLING  
Time: 60/55 s

DRIVE SPEED  
Stowed/Raised: 2.5/0.4 mph



# SPECIFICATIONS

## Size

A	Max. work height	46 ft
b	Max. platform height	39 ft
C	Min. platform height	5 ft
d	Platform length	89.8 in
e	Platform width	45.3 in
f	Max. platform extension length	35.4 in
g	Overall length	98 in
h	Overall length (without ladder)	90.2 in
l	Overall width	47 in
J	Overall height (rails up)	103.5 in
K	Overall height (rails down)	81.5 in
l	Wheelbase	74 in
m	Ground clearance (stowed)	3.9 in
n	Ground clearance (raised)	0.8 in

## Performance

Rated load on working platform	706 lb
Safe working load on extended platform	265 lb
Max. number of workers	2
Drive speed (stowed)	2.5 mph
Drive speed (raised)	0.4 mph
Turning radius (inside)	0 in
Turning radius (outside)	91 in
Raising/falling time	60/55 s
Max. gradeability	25%
Max. working slope (lateral/vertical)	X1.5°/Y3°
Tire size	15x5

## Power

Drive motor	2 hp
Battery	300 Ah
Charger	240V30A

## Weight

Total weight	6,990 lb
--------------	----------

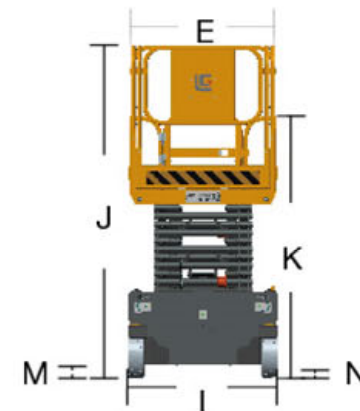
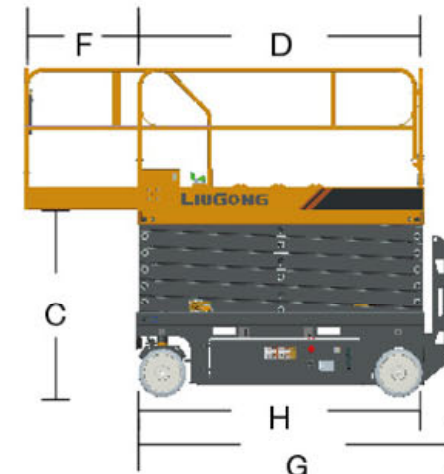
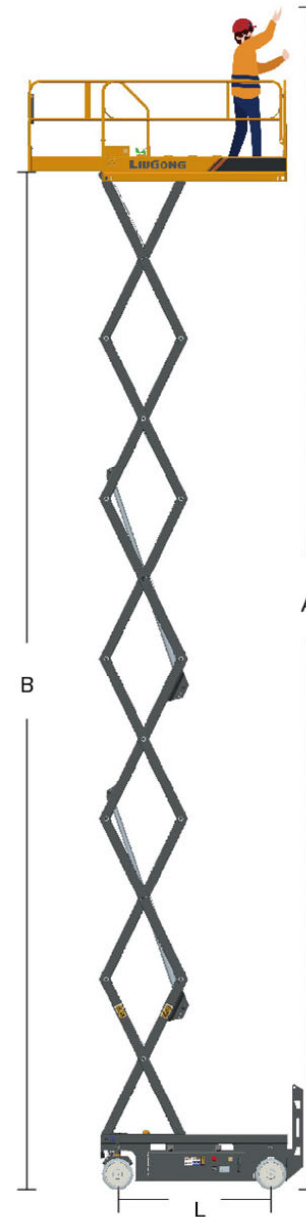

# COMPLIANT WITH ANSI/SAIA STANDARDS

# INCLUDED FEATURES

## STANDARD FEATURES

- Standard longitudinal forklift sprocket hole
- Charging protection system
- Standard lateral forklift sprocket hole
- Adjustable extension platform
- Pothole inspection and protection system
- All motion alarm
- Emergency descent system
- Drop anti-clip function
- Side anti-collision function
- Auto brake system
- 200 V power supply
- Emergency stop button
- Proportional control
- Flashing amber beacon
- Drivable at full height
- Folding guardrails
- Over tilt protective system

## SAFETY AND INTELLIGENCE

- Intelligent control system
- Real-time monitoring of equipment status
- Multiple security protection to ensure personnel safety
- Intelligent charging system to extend the battery service life

## MAINTENANCE FRIENDLY

- Self-lubricating sleeve, no lubrication required
- Rotary tray on left and right sides, easy maintenance
- Fault code indication to facilitate troubleshooting

## EASY TO CONTROL

- Drivable at full height to improve working efficiency
- The proportion drops and the descent moves slowly
- Two-way standard forklift hole, easy to load, unload, and transport

## ACCESORIES & OPTIONS

- Platform working Lights
- Maintenance-free battery
- Wireless remote control system
- Lithium battery
- Airline to platform

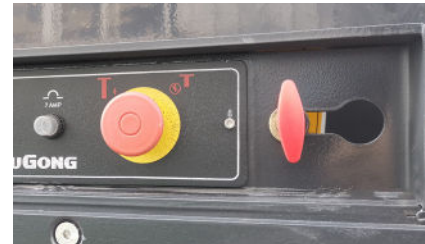

EMERGENCY LOWERING SYSTEM



EXTENDED PLATFORM



SWING-OUT TRAY



FOLDING GUARDRAILS



ACOUSTO-OPTIC WARNING LIGHTS



SAFETY OVERHAUL BRACKET



MAXIMUM GRADEABILITY 25%



STEERING SYSTEM

EXCLUSIVELY FOR DEALER

**LGNA-SS-S4046DE-202301-ENG-US**

Specifications and designs are subject to change without notice.  
Machines shown may include optional equipment.

LiuGong Construction Machinery N.A., LLC.  
22220 Merchants Way - Suite 100  
Katy, TX 77449  
USA

T: 281-579-8882  
[www.liugongna.com](http://www.liugongna.com)

F: 281-579-8388