

2080H

3-SERIES FORK TRUCK

ENGINE
Cummins

RATED POWER
120.7 hp
(90 kW)

CAPACITY
17,637 lb
(8,000 kg)



SPECIFICATIONS

EXCLUSIVELY FOR DEALER

GENERAL

Model	CLG2080H		
Power type	1	Diesel	
Operator Type	2	Sit-Down Rider	
Base capacity	3	@ rated load center	17,637 lb (8,000 kg)
Load center	4	24 in (600 mm)	

WEIGHTS

Service weight	5	unloaded	25,353 lb (11,500 kg)
Axle load	6	loaded/unloaded, front	39,242/12,346 lb (17,800/5,600 kg)
	7	loaded/unloaded, rear	3,748/13,007 lb (1,700/5,900 kg)

TIRES

Tire type	8	Pneumatic	
Wheels	9	front/rear	4/2
Wheelbase	10	102.4 in (2,600 mm)	
Tire size	11	front	9.00-20-14PR
	12	rear	9.00-20-14PR
Tread width	13	front/rear	63/67.7 in (1,600/1,720 mm)

MAST

Max. fork height	14	with std 2-stage mast	118.1 in (3,000 mm)
Free lift	15	with std 2-stage mast	7.9 in (200 mm)
Height, upright lowered	16	with std 2-stage mast	110.3 in (2,801 mm)
Height, upright extended	17	with std 2-stage mast	172.7 in (4,386 mm)
Mast tilt, fwd, back	18	with std 2-stage mast	6°/12°
Carriage	19	width	87.0 in (2,210 mm)
Fork spread	20	minimum/maximum	16.1/83.9 in (410/2,130 mm)
Fork dimensions	21	T x W x L	2.8 x 6.7 x 59.8 in (70 x 170 x 1520 mm)

CHASSIS

Length to fork face	22	with std 2-stage mast	159.4 in (4,050 mm)
Overall width	23	87.0 in (2,210 mm)	
Overhead guard height	24	10.31 in (2,620 mm)	
Turning radius	25	minimum outside	148 in (3,760 mm)
Fork overhang	26	with std 2-stage mast	148.8 in (3,780 mm)
Right angle stack	27	add load length and clearance	29.3 in (745 mm)
Ground clearance	28	minimum loaded	135.4 in (3,440 mm)
	29	center of wheelbase	9.7 in (246 mm)

PERFORMANCE

Model	CLG2080H		
Travel speed	30	loaded/unloaded	11.8/16.2 mph (300/26 km/h)
Lift speed	31	loaded/unloaded	17.4/70.9 fpm (28/0.36 m/s)
Lower speed	32	loaded/unloaded	70.9/98.4 fpm (0.36/0.5 m/s)
Max. drawbar pull	33	loaded	59 lb (0.3kg)
Max. gradeability	34	loaded/unloaded	30%/28%

SYSTEMS

Brakes	35	service	Foot/hyd
	36	parking	Hand/mech
	37	manufacturer	Cummins
	38	model	F3.8
	39	emission compliance	T4F/Tier V
	40	cylinders	4
Engine	41	displacement	3.8 liter
	42	rated power	120.7 hp (90 kW) 2,200 rpm
	43	max. torque	369 lb/ft (500 N/m) 1500 rpm
	44	type	Powershift
Transmission	45	speeds, fwd/rev	2/2
	46	system	3,046 psi (210 bar)
Hydraulic Pressure	47	attachment	2,103 psi (145 bar)

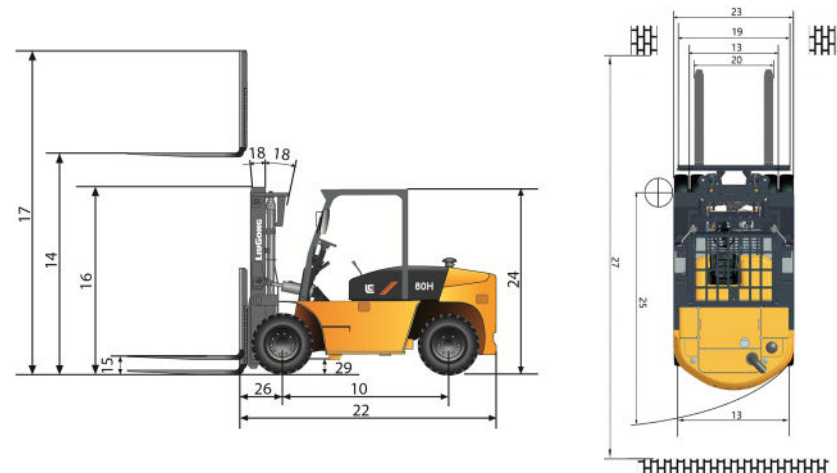

LGNA-SS-2080H-202304-ENG-US

Specifications and designs are subject to change without notice. Machines shown may include optional equipment.

LiuGong Construction Machinery N.A., LLC.
22220 Merchants Way - Suite 100
Katy, TX 77449
USA

T: 281-579-8882
www.liugongna.com

F: 281-579-8388