

# 2160H

3-SERIES FORK TRUCK

ENGINE  
Cummins  
B6.7

RATED POWER  
173 hp  
(129 kW)

CAPACITY  
36,000 lb  
(16,330 kg)

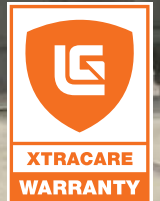

# SPECIFICATIONS

EXCLUSIVELY FOR DEALER

## GENERAL

Model	CLG2160H		
Power type	1	Diesel	
Operator Type	2	Sit-Down Rider	
Base capacity	3	@rated load center	36,000 lb (16,330 kg)
Load center	4	24 in (600 mm)	

## WEIGHTS

Service weight	5	unloaded	44,797 lb (20, 320 kg)
Axle load	6	loaded/unloaded, front	73,138   21,848 lb (33,175/9,910
	7	loaded/unloaded, rear	kg) 7,826/22,950 lb (3550/ 22,950

## TIRES

Tire type	8	Pneumatic	
Wheels	9	front/rear	4/2
Wheelbase	10	137.8 in (3,500 mm)	
Tire size	11	front	12.00-20-18PR
	12	rear	12.00-20-18PR
Tread width	13	front/rear	72.6/83.5 in (1,844/2120 mm)

## MAST

Max. fork height	14	with std 2-stage mast	157.5 in (4,000 mm)
Free lift	15	with std 2-stage mast	3.5 in (90 mm)
Height, upright lowered	16	with std 2-stage mast	152.4 in (3,870 mm)
Height, upright	17	with std 2-stage mast	231.1 in (5,870 mm)
extended Mast tilt, fwd,	18	with std 2-stage mast	6°/ 12°
back Carriage	19	width	96.5 in (2,450 mm)
Fork spread	20	minimum/maximum	18.5/92.5 in (470/2,350 mm)
Fork dimensions	21	T x W x L	3.4x7.9x59.1 (787x200x1500)

## CHASSIS

Length to fork	22	with std 2-stage mast	23	206.7 in (5250 mm)
face Overall width	23	100.4 in (2,550 mm)		
Overhead guard	24	minimum outside	122 in (3,100 mm)	
height Turning radius	25	with std 2-stage mast	187.7 in (4,770 mm)	
Fork overhang	34.4 in (875 mm)			
Right angle stack	26	add load length and clearance	290 in (7,365 mm)	
Ground clearance	27	minimum loaded	11.6 in (295 mm)	
	28	center of wheelbase	13.8 in (350 mm)	

## PERFORMANCE

Model	CLG2160H		
Travel speed	29	loaded/unloaded	14.9/15.5 mph (24/25 km/h)
Lift speed Lower	30	loaded/unloaded	72.8/78.7 fpm (.37/0.4 m/s)
speed Max.	31	loaded/unloaded	80.7 /66.9 fpm (0.4/0.41 m/s)
drawbar pull	32	loaded	28,660 lb (13,000 kg)
Max. gradeability	33	loaded/unloaded	28%/26%

## SYSTEMS

Brakes	34	service	Foot/hyd	
	35	parking	Button/hyd	
	36	manufacturer	Cummins	
	37	model	B6.7	
	38	emission	EPA T4F/Euro Tier V	
	Engine	39	compliance	6
		40	cylinders	6.7 liter
41		displacement	173 hp (129 kW)	
42		rated power	2,200 rpm	
43		max. torque	650 lb/ft (881 N/ m) 1300 rpm	
Transmission	44	type	Powershift	
	45	speeds, fwd/rev	3/3	
Hydraulic Pressure	46	system	2611 psi (180 bar)	
	47	attachment	2,611 psi (180 bar)	

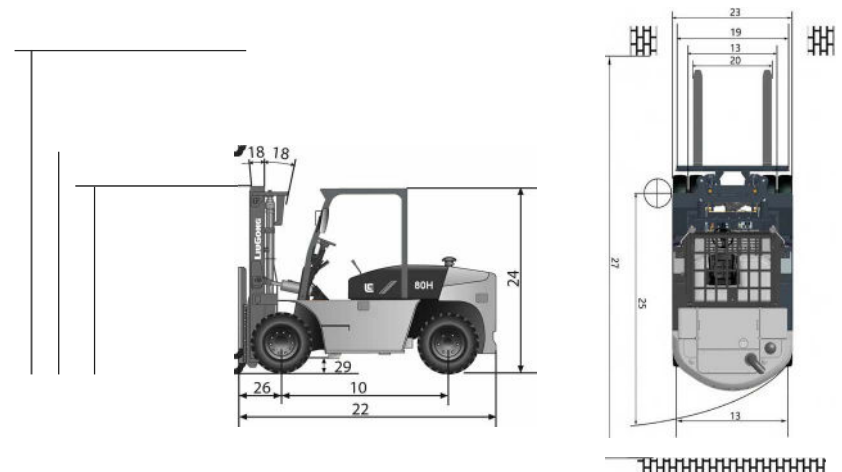

## LGNA-SS-2160H-202406-ENG-US

Specifications and designs are subject to change Machines shown may include optional equipment.

LiuGong Construction Machinery N.A., LLC.  
22220 Merchants Way - Suite 100  
Katy, TX 77449  
USA

T: 281 579-8388  
www.liugongna.com